

Profitpackaging's P3 Applicator Operations Manual

All operators and service personnel should read this manual before operating.

About the Applicator:

The P3 Applicator is a versatile label and ad-note applicator because it can adapt and fit into many different application situations and areas. **Proper set-up and use of recommended label materials and brands will help insure its performance for you.**

For the best trouble free operation we recommend use of the following label stock:

- | | | |
|------------------------|---------------|-----------------------------|
| 1. Address labels: | Avery #4013 | 3-1/2" x 15/16" white label |
| 2. Removable Ad Notes: | Kennedy Group | 3" x 3" |
| | 3-M Corp. | 3" x 3" |

Note: Other label lengths can be accommodated. Longer label lengths require different programming of the servo motor.

If you do order other brands, make sure you refer to the above brands for quality comparisons.

Use of thin web backing paper and weak perforations will only lead to web breakage and rethreading down time. If in doubt, use the above brands. **Down time will cost you more in labor cost than savings realized in using cheaper, less quality labels.**

General overview:

The P3 Applicator uses a precision servo motor for proper label advancement. The direct coupling of the servo motor to the applicator drive shaft eliminates all clutches, chains and other drives found in other applicator designs.

The servo motor is programmed for approximate desired label lengths. The applicator uses an ultrasonic fork label sensor to help correct for any discrepancies in label sizes that may occur. The fork sensor is also used to adjust proper label overhang on the dispense tip.

The automatic dispensing of labels, or notes, is triggered by either:

1. Photo-eye, (for separated products)
2. Optional Laser Lap detector, (for streamed and separated products).
3. Optional Gripper sensor.

Where the product crosses the product sensor determines where the label is placed vertically on the product. Horizontal placement is achieved by where the product passes under the label dispense tip.

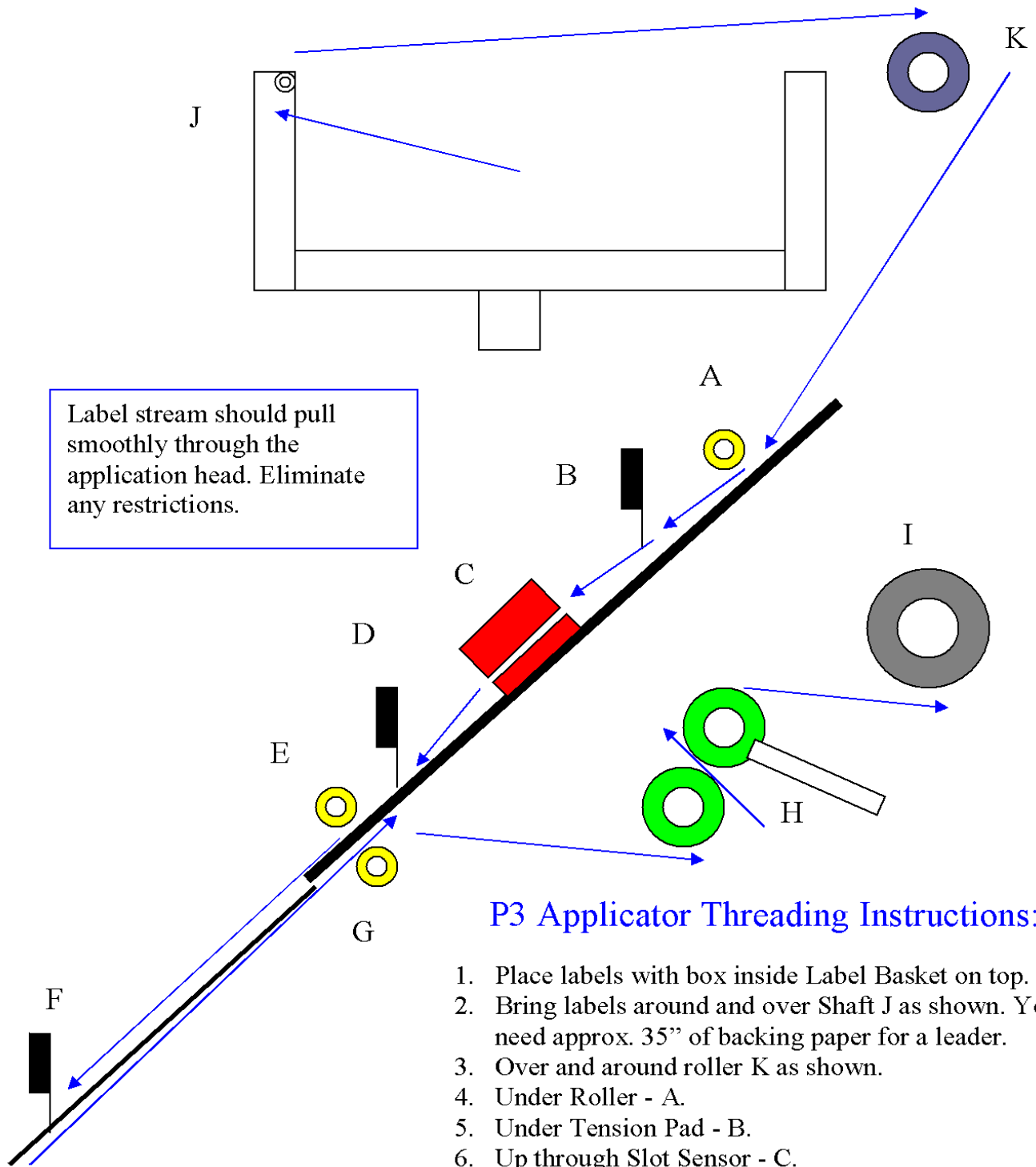

P3 Applicator Threading Instructions:

1. Place labels with box inside Label Basket on top.
2. Bring labels around and over Shaft J as shown. You will need approx. 35" of backing paper for a leader.
3. Over and around roller K as shown.
4. Under Roller - A.
5. Under Tension Pad - B.
6. Up through Slot Sensor - C.
7. Down under Tension Pad - D.
8. Under Roller - E.
9. Under Tension Pad - F.
10. Around Dispense Tip
11. Under Roller - G.
12. Under Drive Roller
13. Open Idler Roller - H (lever on side) and insert web between rollers and bring over idler roller - H.
14. Pull up slack, align backing, and close Idler Roller - sH.
15. Pin backing paper to Take up Spool - I.

Profitpackaging's P3 Applicator Components and Adjustments

(Please refer to page 2 diagram for location)

1. Label Basket

The left side bracket containing the shaft "J" and Roller "K" is to remain fixed. Adjust for different label widths by moving the opposite bracket in or out.

2. Tension Bracket "B"

Set the bracket to slightly restrict the label stream as it passes underneath going up to the slot sensor. **DO NOT SET THIS DOWN SO AS TO PINCH THE STREAM. THIS MAY RESULT IN WEB BREAKAGE OR THE SERVO MOTOR NOT BEING ABLE TO DRIVE PROPERLY.**

3. Slot Sensor "C"

The ultrasonic slot sensor serves two functions:

A. Senses the gap between labels

To adjust the sensor for the gap between labels:

NOTE: This has been factory pre-set and should be performed only by a trained employee or factory representative. Use of the recommended label stock on page one should help alleviate the need for any future adjustment.

1. Place a stream of labels in the slot of the sensor.
2. Align the gap between labels in line with the dot shown in the center of the detection zone. Then push and hold the auto set button marked "normal". After a few seconds the led will flash. The sensor should now sense the gap. The red led will illuminate when the gap is sensed.

B. Adjust the over hang of the label at the dispense tip:

The sensor bracket has been factory marked for reference. **Proper label over hang at the dispense tip is approximately 1/8" for all labels.**

1. The Slot Sensor can be moved up and down the chassis on the plate that it is mounted too.
2. Loosen the two cap head bolts on the sensor bracket. The chassis is slotted to allow upward and downward movement of the sensor.
3. By moving the **sensor down, the label over hang will increase**; likewise by **moving it up, the over hang will decrease.**

NOTE: When changing label lengths such as address to post-it notes, the sensor might have to be slightly adjusted for proper label overhang. Post-it notes should not have more than 1/4" overhang.

4. Adjustable label stream guides:

A. The first two are located on the main chassis "O" as shown below. Loosen the wing nuts underneath and move the guides in to touch but not restrict the label stream. See below diagram.

B. Dispense tip guides.

Located down on the dispense tip "N" as shown below.

The left side is to remain fixed. Label width is adjusted by moving the right side out or in.

To adjust: On the upper adjustment, simply loosen the wing nut. On the lower adjustment, underneath there is a 10-24 bolt that is threaded into the aluminum dispense tip-mounting bracket. This must be loosened along with the wing nut on top.

Move guide in to touch, but not restrict, the label stream. See below diagram.

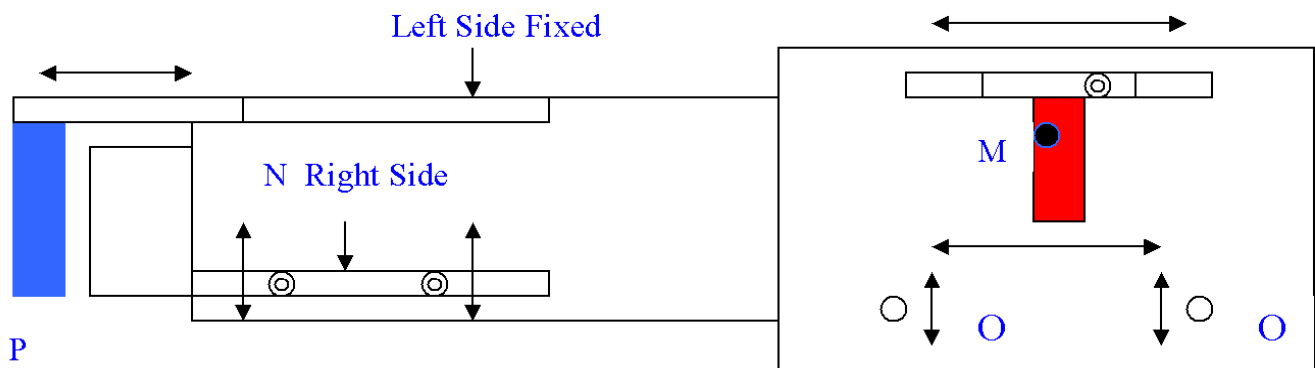

Label press down roller:

1. Adjust roller "P" all the way in for 15/16" Labels.
2. Roller should be as close to the dispense tip as possible.
3. Adjust roller all the way out for 3" Post-it notes.

The roller can be adjusted up and down by using the adjusting knob-screw "L" as shown below.

For all label sizes, adjust the roller so the label shoots down into the bottom of the roller as shown below.

IMPORTANT:

Place product under dispense tip when setting roller and dispense tip height.

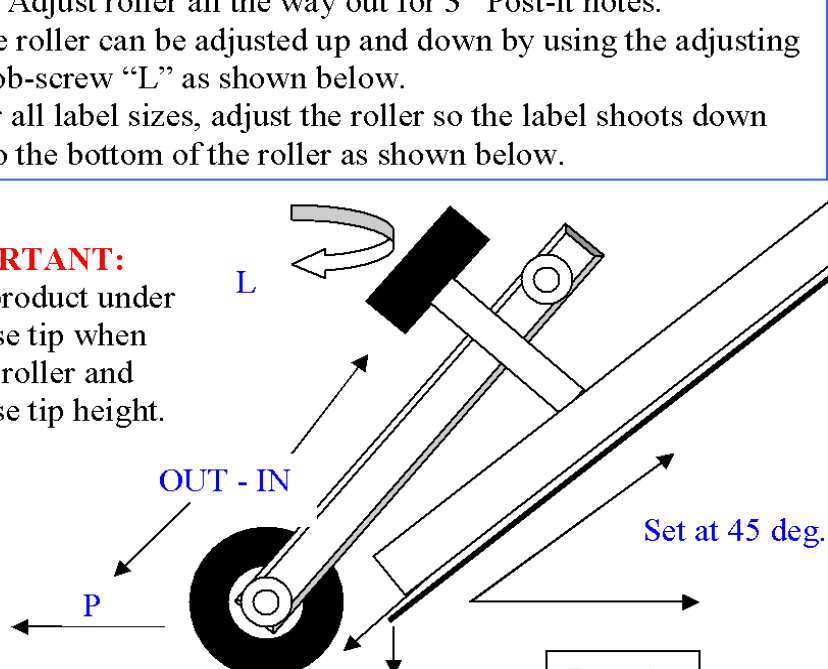

Dispense tip height:

1. 3/8" off of product for 15/16 Labels
 2. 1/2" for 3" Labels.
- See next page.

5. Dispense Tip Height Adjustment

IMPORTANT: The height and angle of the dispense tip in relation to the product is the most important adjustment on the Applicator. **The angle between the product and the tip should be set as close to 45 degrees as possible.** The label should dispense smoothly onto the product. If the angle is too steep, the label will bend or fold when hitting the product and not apply or adhere properly. **The angle of the head is adjusted by the large adjusting knob located by the label basket.**

To adjust:

1. With the head adjusted at 45 degrees, lower the head down onto the product keeping the desired dispense tip height. Adjust the press down roller as shown.
2. Run test product by and watch how label dispenses and adheres to the product.
3. Adjust head up or down and angle as required.
4. If the product is coming by at an angle then the head dispense angle must still be adjusted to 45 degrees in reference to that angle. See below:

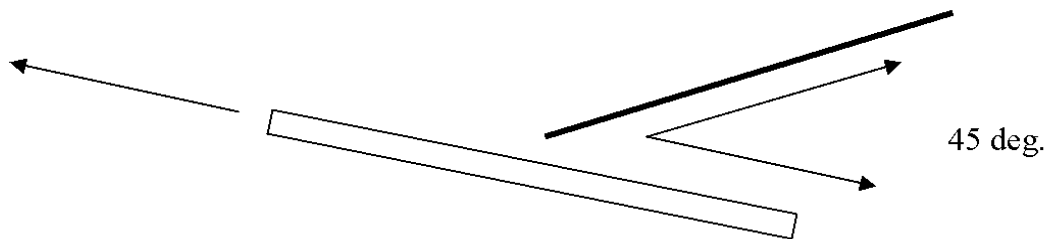

6. Label Placement:

1. Moving the product sensor in or out adjusts for where the label is applied.
2. Out moves the label placement towards the masthead.
3. In moves the label placement towards the leading edge.
4. Make sure the sensor is properly positioned over the reflective area below.
5. **Important:** The Photo Sensor requires at least a 1" minimum gap between products. Set input conveying speed to properly accomplish this.
6. If the conveyor input speed is increased or decreased after initial set up, then the sensor may have to be re-positioned for desired label position.

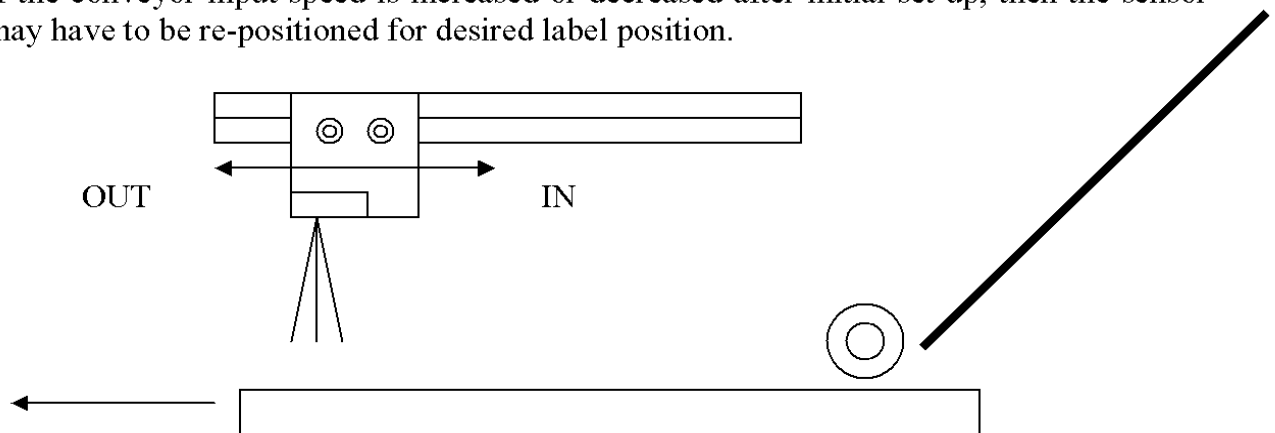

7. Electrical and Control System

The Applicator runs on 120 VAC 10AMP service. **IMPORTANT: All care should be taken to insure this line is isolated and free of potential electrical spikes and noise.** The Applicator should be unplugged from its power source after operation.

The servo motor, controls, and sensors are powered by 24 VDC. The servo motor is programmed through an optical I/O board located in the control box. All inputs and outputs originate here. The programming is accessible only by factory personnel.

To Operate:

1. Plug in Power Cord.
2. Turn Power switch to the ON Position.
3. Select desired label size. Switch position 1", will control 0-1" labels, Switch position 3" will operate 1" plus up to 3". Switch position 4" will operate 3" plus up to 4".

The Applicator will stop labeling if the Power switch is turned to the OFF position.

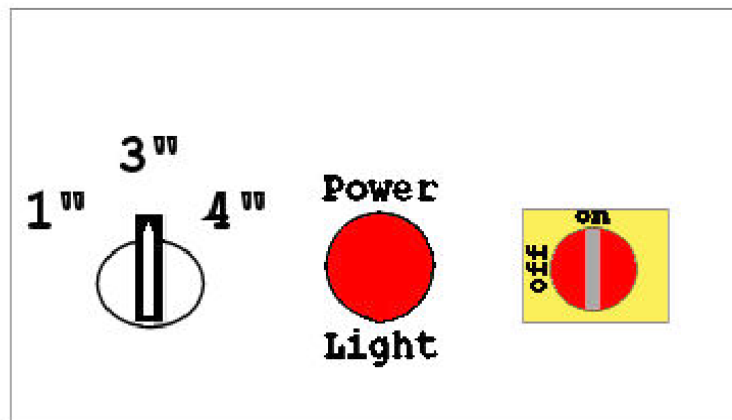

Trouble Shooting

Adjusting the applying head angle and dispense tip height and label overhang properly can solve most problems.

Double Labeling:

1. **Make sure dispense tip isn't too far away from the product.**
The label must dispense onto the product immediately and not float off of the tip.
2. **Check dispense tip label overhang.** Product might be catching label as it passes underneath. Address labels must not have more than 1/8" overhang. Adjust accordingly.
3. Make sure you are in the right label size mode on control console.
4. Check product sensor for proper alignment. Make sure the sensor isn't giving off a double signal or a signal when the product isn't present. See line noise below.
5. Check slot sensor for proper functioning. **Dust build up may occur in the bottom sensor area.**

Erratic Label placement:

1. Dispense tip too high off of paper or too close.
2. Applying head angle too steep to product.
3. Label press down roller set too far away from applying area.
4. Wrong label size mode selected.
5. Products not crossing under product sensor properly.
6. Products jamming under dispense tip.
7. Idler drive rollers aren't engaged.

Ad note folding up as it is applied to product:

1. Dispense tip too close to the paper. Notes need to be at least 1/2" off of the product.

Intermittent misses:

1. Product not crossing product detector.
2. **Product sensor reflective tape is dirty or worn out.**
3. Product sensor out of alignment.

Web breaking:

1. Weak perforated labels.
2. Label perforations broke by prior printing process.
3. Label backing paper too thin.
4. Restriction in label stream.
5. Tension pads set too tight.

Note: Some label brands are not made for use in automated applying equipment.

Line noise can contribute to label miss-firing and doubles. Try not to have power location in areas where strappers, bottom wraps etc... are operating. If it is, make sure proper line filters are installed.

Maintenance

1. Keep Applicator blown off and clean.
2. A gummy residue may build up on the drive and idler rollers. Clean residue off when this occurs. Residue usually occurs from removable notes.
3. The waste liner take-up belt may become stretched after a period of use. Lightly apply belt dressing to the belt to improve gripping.
4. All main drive bearings should not need lubrication for at least a year if at all.
5. The main drive idler roller and label press down roller have bronze bushings that require a few drops of oil applied to them once a month.
6. Check sensors for dust build up.
7. Remove any labels stuck in slot sensor area.

Parts Ordering:

Please refer to page 2 diagram for any OEM parts.

Other misc. parts:

1. P3 Tritron Slot Sensor
2. P3 Product Photo Eye
3. Waste Take Up Belt
4. P3 Servo Motor
5. P3 Optic Board

Warranty

All parts manufactured by Profitpackaging, Inc. are warranted for 2 years. All purchase parts used in the manufacture of the P3 Applicator are subject to their manufacture's warranty. Electronic parts and returns will be subject to original OEM manufacture's inspection, shipping costs and repair costs before credit is given.

For more information and service please call:
660-438-7090